

DATA SHEET:

BE.20.S.NT

BREATHER DRAIN M20 STAINLESS STEEL

TYPE 'BE' BREATHER DRAINS ARE USED TO ALLOW THE AIR INSIDE AN ENCLOSURE TO BREATHE WITH THE SURROUNDING ATMOSPHERE AND ALSO TO ALLOW ANY MOISTURE THAT ENTERS THE ENCLOSURE TO DRAIN WHILE MAINTAINING THE OVERALL INTEGRITY OF THE INSTALLATION.



www.hlsus.com

Type:Be

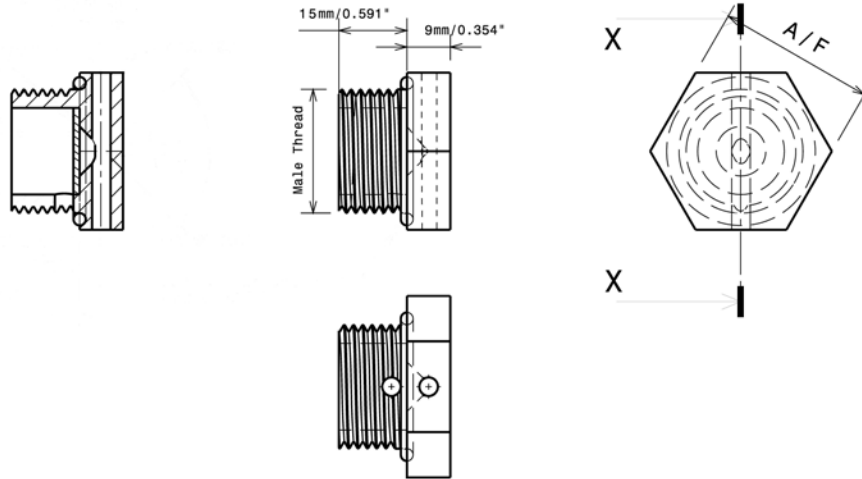

Type:Be

Castellated Locknut

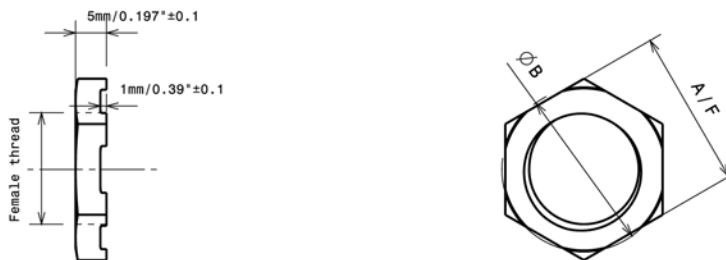

Approvals & Specifications

- ATEX/IEC Exe II / Ex tb IIIC IP66
EN/IEC 60079-0, EN/IEC 60079-7, EN/IEC 60079-31
ATEX/94/9/EC
- NEC/CEC AExe II Class I, Zone 1
UL2279, UL60079-0, UL60079-7, UL60079-1-1
E60079-0, E60079-7, E60079-1-1
- Material 316 Stainless Steel (-50 to +850°C)
Passivated
- 'O'rings Nitrile (-30 to +80°C)
- Thread Metric Medium Fit 6g
- Gauging
- Ingress Protection IP 66, NEMA 4X
- Impact Resistance 7 Nm

Dimensions

Part Number	Be.20.S.NT
Male Thread	M20 1.5 Pitch
Male Thread Length 'A'	0.591" (15.0mm)
Hex A/F	1.00" (25.4mm)