

DATA SHEET:

U5.20.S.NT

Type 'U' Stopping Plugs are used to seal unused cable gland or conduit entries in Ex approved enclosures, maintaining the hazardous location certification and the overall integrity of the installation.

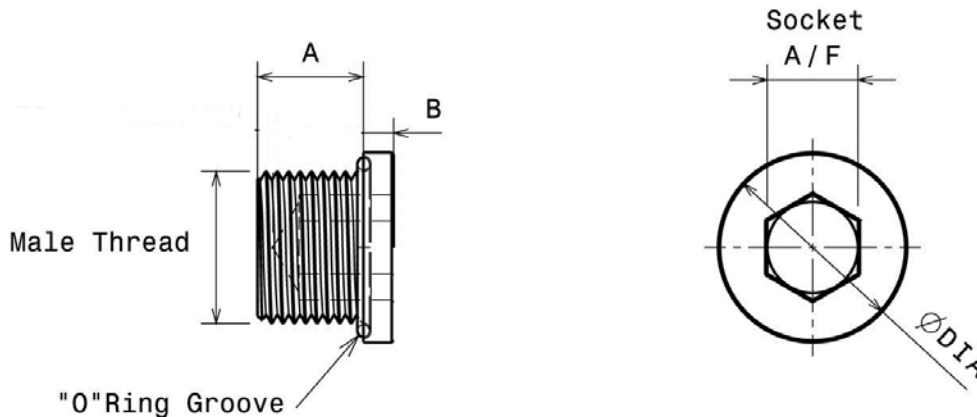

Approvals & Specifications

ATEX/IEC Exd IIC Gb / Exe IIC Gb / Extb IIC Db, IP6X
EN/IEC60079-0, EN/IEC60079-1, EN/IEC60079-7, EN/
IEC60079-31, ATEX/94/9/EC II 2GD

NEC/CEC Class I, Division 1, Groups ABCD
Class II, Division 2, Groups EFG, Class III
UL1203, UL514B, UL50
C22.2 Nos. 30, 0.5, 0-M, 45, 18.3-04, 94-M91
AExd IIC / AExe II Class I, Zone 1
UL2279, UL60079-0, UL60079-1, UL60079-7, UL60079-1-1
E60079-0, E60079-1, E60079-7, E60079-1-1

Thread Gauging Metric Male: 1.5mm Pitch- Medium Fit 6g

Material 'O' Ring 316 Stainless Steel 'S' (-100 to +850°C)
Nitrile (-30 to +90°C)

Ingress Protection With 'O' Ring IP 66 68, NEMA 4X
With Thread Sealant (Non-Hardening) IP 66 68
NEMA 4X
Without 'O' Ring or Thread Sealant IP54

Impact Resistance 7Nm

Dimensions	
Part Number	U5.20.S.NT
Male Thread	M20 x 1.5mm
Male Thread Length 'A'	0.63" (16.0mm)
Head Dia	1.024" (26.0mm)
Head Width 'B'	0.157" (4.0mm)
Socket A/F	10mm